

# Emerald TurboVap Series Evaporators

## Reduced Size, Noise & Power Draw



The Emerald TurboVap series of split-gas evaporators for boats incorporates revolutionary design features with mechanical engineering that maximizes the effectiveness of R-410A, an environmentally safe refrigerant.

Emerald TurboVaps are easy to install. For ideal positioning, the high-velocity blower can rotate up to 270 degrees with a single adjustment screw. The enclosed motor means no blower-motor overhang for a compact design.

Since evaporators are usually positioned in or near cabins, noise is always a concern. The Emerald TurboVap uses a vibration-isolation mounting system to minimize noise, so the evaporator runs more quietly. The fully insulated, high-velocity blowers are quiet and efficient.

Excellent condensate drainage is achieved with a unique positive-flow, anti-slosh, composite drain pan that is rust-free. Condensate water is rapidly removed at one of two easy-to-plumb drain locations.

The Emerald TurboVap Series was designed to operate as a system with the Emerald Condenser Series. Both of these split-system components were engineered to harness and maximize the superior thermodynamic properties of the environmentally safe R-410A refrigerant.

The Emerald TurboVap is available in six capacities ranging from 4,000 to 16,000 BTU/hr.



The rust-free composite drain pan reduces standing water up to 85%, thanks to "positive-flow" drain channels. These channels also help prevent spilling and sloshing in rough seas.



Optional lineset extensions for discharge and suction are available for all TurboVap models.

### Key Benefits

- Up to 28% reduced amperage
- Up to 85% reduction in standing water in the drain pan
- Up to 14% increase in cooling capacity
- Up to 15% lighter
- Up to 17% reduction in height
- Up to 19% increased air flow CFM
- Rust-free composite drain pan
- Drain pan features anti-slosh, "positive-flow" drain channels for no spills and rapid removal of condensate
- Up to 15 minutes faster to install
- Single adjustment screw for 270° of blower rotation
- High-velocity (HV) fully-insulated blowers are rotatable
- Vibration-isolation mounts reduce noise and vibration
- 115V and 230V models
- Designed to be used with Emerald Series (R-410A) condensers

## Specifications for Emerald TurboVap Series Evaporators

Model <sup>(1)</sup>	TVE4		TVE6		TVE8		TVE10		TVE12		TVE16	
Capacity (BTU/h)	4000		6000		8000		10000		12000		16000	
Voltage @ 50/60Hz 1-Ph (V)	115	230	115	230	115	230	115	230	115	230	115	230
Full Load Amps (FLA) Cool (A)	0.82	0.41	0.82	0.41	1.56	0.83	1.14	0.61	1.14	0.61	1.61	0.78
Max. Circuit Breaker (A)	5		5		5		5		5		5	
Min. Circuit Ampacity (A)	2	1	2	1	2		2	1	2	1	3	1
Height-Coil (in/mm) <sup>(2)</sup>	10.8/275		10.8/275		10.8/275		12.6/321		12.6/321		13/331	
Height-Blower (in/mm) <sup>(2)</sup>	10.8/275		10.8/275		11.4/290		12.6/321		12.6/321		13.6/346	
Width (in/mm) <sup>(2)</sup>	12.3/313		12.3/313		12.3/313		14.3/364		14.3/364		14.3/364	
Depth (in/mm) <sup>(2)</sup>	9.5/242		9.5/242		9.4/239		10.4/265		10.4/265		11.6/295	
Min. Supply Duct Size (in/mm)	4/102		4/102		5/127		6/153		6/153		7/178	
Min. Supply Air Grille Size (sq in/sq cm)	32/207		32/207		48/310		60/388		70/452		81/523	
Min. Return Air Grille Size (sq in/sq cm)	64/413		64/413		80/517		110/710		130/839		160/1033	
Net Weight (lbs/kg) <sup>(3)</sup>	10.5/4.8	11.25/5.2	12/5.5	12.25/5.6	14/6.4		17.5/8		17.5/8	17.75/8.1	20.5/9.3	21/9.6
Gross Weight (lbs/kg) <sup>(3)</sup>	18.5/8.4	18/8.2	19/8.7	20.25/9.2	22/10		25.5/11.6	25/11.4	25.5/11.6	24.75/11.3	28/12.8	28.5/13

<sup>1</sup> Add "115V" or "230V" to the model number for 115V and 230V units, respectively.

<sup>2</sup> All dimensions ± 0.30 in. (8 mm).

<sup>3</sup> All weights ± 10%

## Dimensions

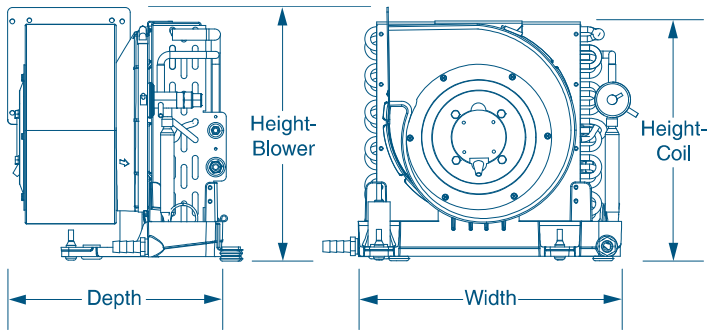

### DOMETIC MARINE DIVISION

2000 N. Andrews Ave. Ext. | Pompano Beach, FL 33069 USA | Tel. 954-973-2477 | Fax: 954-979-4414  
[www.Dometic.com/Marine](http://www.Dometic.com/Marine) | [MarineSales@DometicUSA.com](mailto:MarineSales@DometicUSA.com)

### 24/7 TECH SUPPORT FOR UNITED STATES & CANADA:

8:00 AM to 5:00 PM Eastern Time: 800-542-2477  
 After hours and weekends: 888-440-4494

### INTERNATIONAL SALES & SERVICES

Europe & the Middle East: Call +44(0)870-330-6101  
 For all other areas visit our website to find your nearest distributor.

L-2696B Rev. 20120803

Specifications and availability subject to change without notice.



MARINE / CARAVAN REFRIGERATION & AIRCONDITIONING  
 CARAVAN REPAIRS

☎ 07 3286 3522 📍 259 South Street, Cleveland QLD 4163