

Compact Series Multi-Ton Air Conditioning

High-Capacity Air Conditioning In a Compact Package



27,000 BTU/hr Compact unit shown

The Compact series of self-contained marine air conditioners offers 18,000 and 27,000, and 30,000 BTU/hr of reverse-cycle cooling and heating.

These high-capacity units were engineered to harness and maximize the impressive performance of environmentally safe R-410A refrigerant. Used in the HVAC industry for more than 10 years, R-410A is proven and reliable, complies with all EPA standards, and is accepted worldwide.

All models offer direct expansion operation in a compact, low-profile unit, with a seawater-cooled condenser and choice of controls. Compact units are designed for installation under a settee or berth, in a locker or cabinet, or other convenient location.

Compact systems feature high-velocity (HV) blowers. All blowers are insulated to prevent secondary condensation, and are fully rotatable for flexibility during installation. A stainless-steel chassis is standard on all Compact models.

The 30,000 BTU/h model features dual evaporator coils and a single compressor on a single chassis. The dual high-velocity (HV) blowers can be ducted to two or more interior spaces.



The dual-blower 30,000 BTU/hr unit with stainless-steel chassis.

Key Benefits

- Compact design reduces unit size by up to 25% of the original Vector Rotary's size
- High-velocity (HV) fully-insulated blowers are rotatable
- Patented design increases cooling capacity and dehumidification
- Engineered to maximize the performance of R-410A, an environmentally safe refrigerant
- Unique compressor and reversing valve mounting reduces vibration
- Electrical box is installed within unit footprint on 18K and 27K models; remotely mounted for 30K models
- High-efficiency rotary and scroll compressors are quiet and more reliable
- Condenser coil's cupronickel-encased copper condenser coil provides maximum heat transfer and high resistance to corrosion
- Evaporator coil employs an enhanced fin design and rifled copper tubing to provide maximum capacity
- 27K and 30K models available in 3-phase power on a special order basis
- 5 ft. (1.5 m) air sensor standard
- Operates with select Cruisair or Marine Air displays

Special Options

- Display cable



Specifications for Compact Series Multi-Ton Air Conditioning

Model ⁽¹⁾	DCU18			DCU27		SVCD30	
Capacity (BTU/h) ⁽²⁾	18000			27000		30000	
Voltage (V)	115	230	220	230	220	230	380
Cycle (Hz) ⁽³⁾ /Phase (Ph)	60/1		50/1	60/1	50/1	60/1	50/3
Full Load Amps (FLA) Cool (A)	11.1	6.4	5.7	8	7.6	9.7	4.96
Full Load Amps (FLA) Heat (A)	15.1	8.3	7	11.2	11	12.8	5.96
Full Load Amps (FLA) Blower (A)	1.93	1.15		1.64		1.76	1.56
Locked Rotor Amps (LRA) (A)	66	32	26	58.3	60	53	38
Max. Circuit Breaker (A)	45	20		45	40	35	15
Min. Circuit Ampacity (A)	27	13		27	24	21	10
Refrigerant Type	410A			410A		410A	
Height-Coil (in/mm) ⁽⁴⁾	14/356			18/458		N/A	N/A
Height-Blower (in/mm) ⁽⁴⁾	15.5/394			19.25/489		N/A	N/A
Height-Compressor (in/mm) ⁽⁴⁾	N/A			N/A		15/381	16.5/420
Width (in/mm) ⁽⁴⁾	21/534			24.75/629		25/635	
Depth (in/mm) ⁽⁴⁾	12/305			15.25/388		23/585	
Min. Supply Duct Size (in/mm)	7/178			8/204		5/127	
Quantity-Duct Connections	1			1		2	
Min. Supply Air Grille Size (sq in/sq cm)	100/646			140/904		150/968	
Min. Return Air Grille Size (sq in/sq cm)	200/1291			240/1549		250/1613	
Seawater Inlet Connection (in/mm)	5/8 /16			5/8 /16		5/16	
Net Weight (lbs/kg) ⁽⁵⁾	64/29.1	69.45/31.6	70/31.8	120/54.5		108.25/49.2	TBD
Gross Weight (lbs/kg) ⁽⁵⁾	73/33.2	81/36.8	82/37.2	130/59		125/57.4	TBD

¹ To complete the model numbers for a specific voltage/cycle/phase, add a '-1161' for 115V/60Hz/1-Phase, or '-2361' for 230V/60Hz/1-Phase, followed by '-410A' (e.g. DCU27-2361-410A).

² BTU and electrical data are based on a 45°F/7.2°C evaporator and 100°F/37.8°C condenser in cool mode, and a 45°F/7.2°C evaporator and 130°F/54.4°C condenser in heat mode.

³ 60Hz units must not operate at 50Hz and 50Hz units must not operate at 60Hz unless data plate states otherwise.

⁴ All dimensions ± 0.30 in. (8 mm).

⁵ All weights ± 10%

Dimensions

Single-Blower 18,000 & 27,000 BTU/h Models

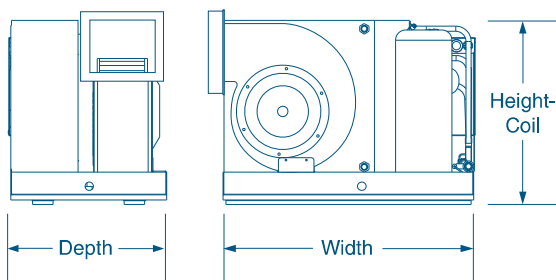

Dual-Blower 30,000 BTU/h Model

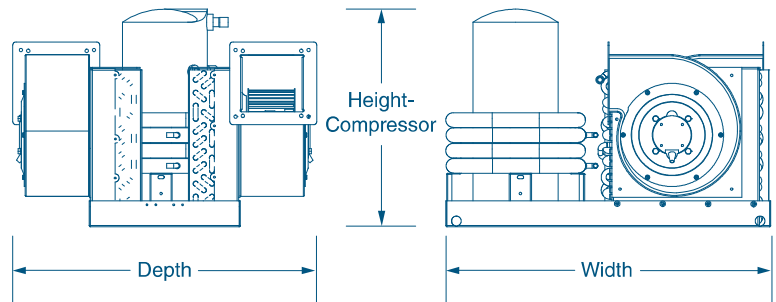

DOMETIC MARINE DIVISION

2000 N. Andrews Ave. Ext. | Pompano Beach, FL 33069 USA | Tel. 954-973-2477 | Fax: 954-979-4414
www.Dometic.com/Marine | MarineSales@DometicUSA.com

24/7 TECH SUPPORT FOR UNITED STATES & CANADA:

8:00 AM to 5:00 PM Eastern Time: 800-542-2477
After hours and weekends: 888-440-4494

INTERNATIONAL SALES & SERVICES

Europe & the Middle East: Call +44(0)870-330-6101
For all other areas visit our website to find your nearest distributor.

L-2769 Rev. 20160205

Specifications and availability subject to change without notice.



MARINE / CARAVAN REFRIGERATION & AIRCONDITIONING
CARAVAN REPAIRS

☎ 07 3286 3522 📍 259 South Street, Cleveland QLD 4163