

NEW!

Emerald Condenser 6K-16K Series

Innovative Chassis Conquers Installation Challenges

Photo courtesy of Viking Yachts



EQ12 shown

After listening to boat builders, global service teams and boat owners, Dometic engineers designed a totally innovative Emerald Condenser series to harness and maximize the impressive performance of R-410A refrigerant while meeting all international clean air standards.

The increase in BTU capacity is due primarily to the improved refrigerant metering design. The bi-flow thermal expansion valve for cooling provides up to a 14% increase in system capacity, which, when combined with a separate metering system for heating, attains an increase of up to 10% in heating performance. The amperage reduction of up to 27% is due to the more efficient design of the rotary compressor and properly sized refrigerant components.

The Emerald Condenser has a minimized footprint. This compact design incorporates built-in isolation, two large drain connections and numerous mounting options for installation to a smooth deck, stringer or existing rack. The incorporated lifting handles and smooth bottom allows for easy lifting and quick placement of the unit. The molded composite no-rust drain pan is shaped to provide positive drainage even when the boat heaves and rolls. The amount of standing water in the drain pan is reduced by up to 85%, which is 8x times less than a typical drain pan.

The condensing unit provides quick and easy installation. The drain, seawater and refrigerant connections are conveniently located to conquer installation challenges thus reducing installation time by up to fifteen minutes. The electrical box can be easily removed and located up to 5 ft. (1.5 m) away, further reducing the size of the unit while making the system more accessible. The reversing valve, pressure switches and service ports are centrally located, high on the unit for access from any side.

ISO 9001:2008

L-2702A Rev. 20100604

Key Benefits

- Up to 17.5% increase in BTU capacity.
- Up to 41% amperage reduction.
- Up to 32% reduced start-up amps.
- Up to 16% smaller.
- Up to 25% lighter.
- Up to 85% reduction in condensate in the drain pan.
- Up to 15 minutes faster to install.
- Square chassis for easy installation in tight locations.
- Three mounting options adapt to installation environments.
- Composite drain pan will not rust.
- Reconfigurable chassis allows optimal drain connection locations.
- Built-in refrigerant-line filter drier reduces installation time and protects compressor from moisture and contaminants.
- High-performance engineering maximizes the efficiency of R-410A refrigerant.
- Available in capacities ranging from 6K to 48K BTU/hr.

Cruisair[®]
by Dometic GROUP

Technical Specifications for Emerald Condenser 6K-16K Series

Model ⁽¹⁾	EQ6			EQ8			EQ10			EQ12			EQ16		
Capacity (BTU/Hr)	6,000			8,000			10,000			12,000			16,000		
Power (Volt/Hz/Ph)	115/60/1	230/60/1	240/50/1	115/60/1	230/60/1	240/50/1	115/60/1	230/60/1	240/50/1	115/60/1	230/60/1	240/50/1	115/60/1	230/60/1	240/50/1
Full Load Amps (FLA) – Cool	3.8	1.8	2.4	4.2	2.4	2.4	5.6	2.6	2.4	7.6	3.4	2.8	8.8	4.3	4.0
Full Load Amps (FLA) – Heat	5.1	2.4	3.3	5.8	3.3	3.3	7.7	3.3	3.3	9.8	4.5	3.8	12.0	5.8	5.3
Locked Rotor Amps	36.0	17.7	17.7	36.0	17.7	17.7	42.0	22.0	18.8	58.0	28.0	21.0	62.0	34.0	22.0
Max. Circuit Breaker (Amps)	20.0	10.0	10.0	20.0	10.0	10.0	30.0	10.0	10.0	35.0	15.0	10.0	45.0	15.0	15.0
Refrigerant Type	R-410A			R-410A			R-410A			R-410A			R-410A		
Seawater Flow (gpm/lpm)	1.5/5.7			2.0/7.6			2.5/9.5			3.0/11.4			4.0/15.1		
Unit Dimensions (in/mm)															
Height	12.0/305			12.0/305			13.0/330			13.0/330			14.1/358		
Width	13.3/338			13.3/338			13.3/338			13.3/338			13.3/338		
Depth 1 ²	13.3/338			13.3/338			13.3/338			13.3/338			13.3/338		
Depth 2 (w/elec. box) ³	15.1/384			15.1/384			15.1/384			15.1/384			15.1/384		
Connections Ø															
Sea Water (in. and type)	5/8" hose clamp			5/8" hose clamp			5/8" hose clamp			5/8" hose clamp			5/8" hose clamp		
Discharge	1/4"			1/4"			1/4"			1/4"			1/4"		
Suction	3/8"			3/8"			3/8"			3/8"			1/2"		
Weights (lbs./kg.)															
Net Weight	43.0/19.5			43.0/19.5			45.0/20.4			47.0/21.3			49.0/22.2		
Gross Weight	50.0/22.7			50.0/22.7			52.0/23.6			54.0/24.5			56.0/25.4		

Notes:

- ⁽¹⁾ EQ models have a Q-Logic control. For units with a mechanical control, replace the "Q" with "M", e.g. "EM16".
- ⁽²⁾ Actual unit depth when electrical box is mounted remotely.
- ⁽³⁾ Combined depth of unit and electrical box, as shown in the drawing below.

* Please refer to spec sheet L-2702B for the Emerald Condenser 24K-48K Series.

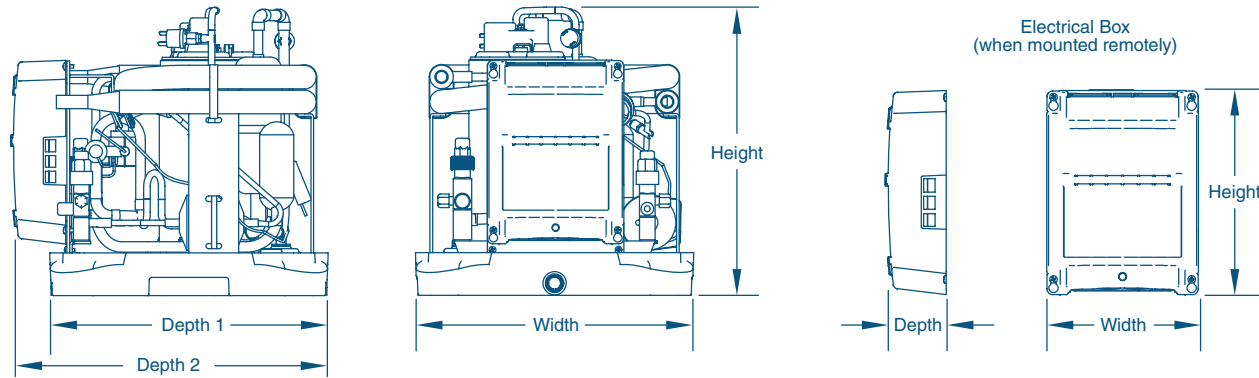

Electrical Box Dimensions (in/mm)

Height	Width	Depth
8.75/222	6.50/165	2.63/67

DOMETIC MARINE DIVISION

2000 N. Andrews Ave. Ext. I Pompano Beach, FL 33069 USA | 954-973-2477 | Fax 954-979-4414
www.DometicUSA.com | MarineSales@DometicUSA.com

24/7 Tech Support for United States & Canada:

8:00 AM to 5:00 PM Eastern Time: 800-542-2477

After hours and weekends: 888-440-4494

International Sales & Service:

Europe & the Middle East: Call +44(0)870-330-6101

For all other areas visit our website to find your nearest distributor.



Dealer: